

GB **Forced draught gas burner**

CN **强制通风燃气燃烧器**

One stage operation

一段火运行

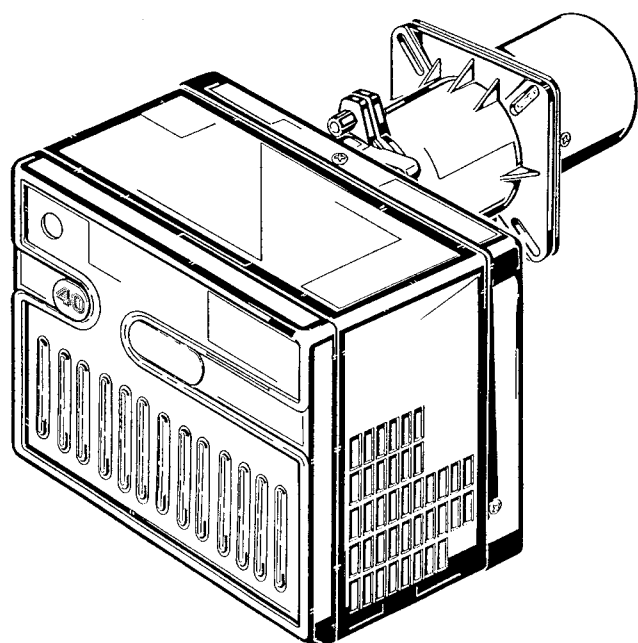

CODE - 编码

MODEL - 型号

TYPE - 类型

20013621

FS20

569T30

INDEX

1. BURNER DESCRIPTION	1	4. WORKING	6
1.1 Burner equipment	1	4.1 Combustion adjustment.	6
2. TECHNICAL DATA	2	4.2 Combustion head setting.	6
2.1 Technical data.	2	4.3 Air damper setting.	7
2.2 Overall dimensions	2	4.4 Combustion check.	7
2.3 Working field	2	4.5 Air pressure switch	7
3. INSTALLATION	3	4.6 Burner start-up cycle.	8
3.1 Boiler fixing	3	4.7 Start-up cycle diagnostics	8
3.2 Probe-electrode positioning.	4	4.8 Resetting the control box and using diagnostics	9
3.3 Gas feeding line	4	5. WARNINGS	
3.4 Electrical wiring.	5	to avoid burnout or bad combustion of the burner	10
3.4.1 Standard electrical wiring	5	6. MAINTENANCE	10
3.4.2 Electrical wiring with gas leak control device	6	7. FAULTS / SOLUTIONS	11

1. BURNER DESCRIPTION

Gas burner with one stage working.

- According to Directives: EMC 89/336/EEC - 2004/108/EC, Low Voltage 73/23/EEC - 2006/95/EC and Efficiency 92/42/EEC.
- The burner is approved for intermittent operation as per Directive EN 676.
- The burner meets protection level of IP X0D (IP 40), EN 60529.
- Gas train according to EN 676.

- 1 – Air damper
- 2 – Screws for fixing the air-damper
- 3 – 7 pole socket for electrical supply and control
- 4 – 6 pole socket for gas train
- 5 – Cable grommet
- 6 – Screw for fixing the cover
- 7 – Air pressure switch
- 8 – Control box
- 9 – Reset button with lock-out lamp

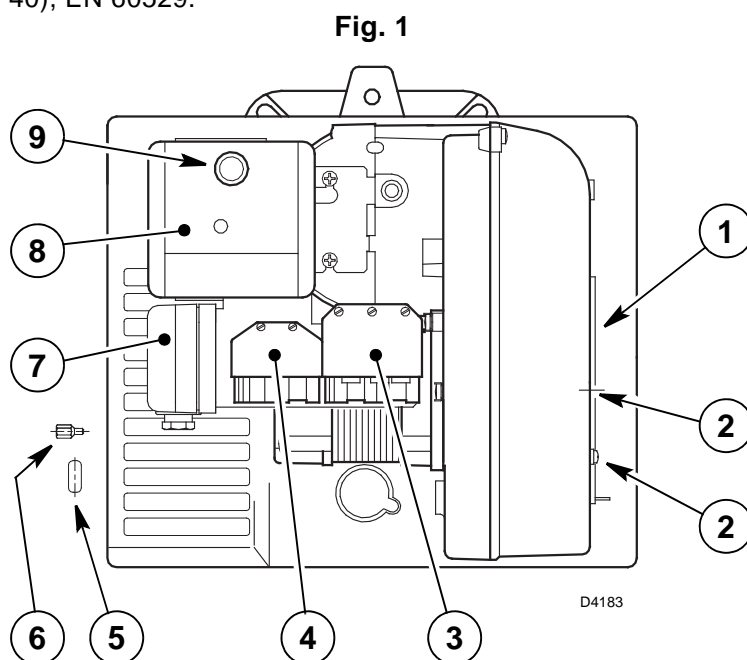

NOTES:

- The cable grommet (5) supplied with the burner, must be fitted to the same side of the gas train.
- After having installed the burner verify the access to the fixing screws of the cover. If necessary replace them with the fixing screws (6, fig. 1) supplied as equipment.

1.1 BURNER EQUIPMENT

Insulating gasket	No. 1	Screws and nuts for flange to be fixed to boiler	No. 4
Cable grommet.	No. 1	Screws for fixing the cover.	No. 3
Hinge	No. 1	7 pin plug.	No. 1

2. TECHNICAL DATA

2.1 TECHNICAL DATA

Thermal power (1)	81 – 220 kW - 70,000 – 189,000 kcal/h
Natural gas (Family 2)	Net heat value: 8 – 12 kWh/Nm ³ - 7,000 – 10,340 kcal/Nm ³
	Pressure: min. 20 mbar - max. 100 mbar
Electrical supply	Single phase, 230V ± 10% ~ 50Hz
Motor	230V / 1.4A
Capacitor	5 µF
Ignition transformer	Primary 230V / 1.8A - Secondary 8 kV / 30 mA
Absorbed electrical power	0.25 kW
(1) Reference conditions: Temp. 20°C - Barometric pressure 1013 mbar – Altitude 0 m above sea level.	

For gas family 3 (LPG) ask for separate kit.

COUNTRY	DE	AT - GR	FR	ES - GB - IE	LU	NL
GAS CATEGORY	II2ELL3B/P	II2H3B/P	II2Er3P	II2H3P	II2E3B/P	II2L3B/P

2.2 OVERALL DIMENSIONS

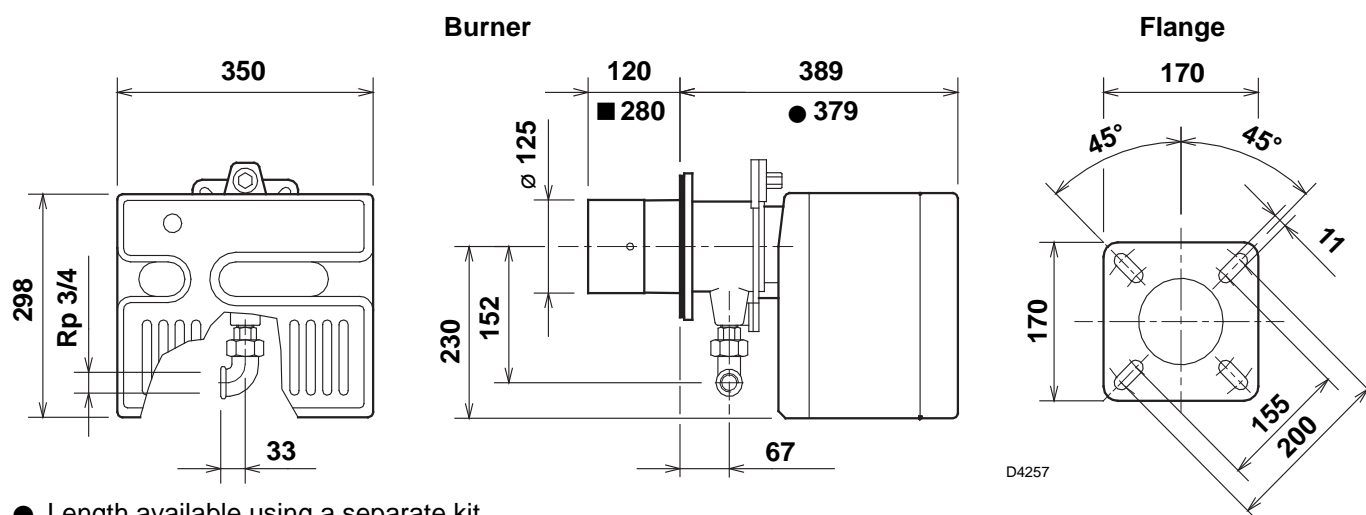

- Length available using a separate kit.
- Combustion head extension, supplied separately.

2.3 WORKING FIELD (as EN 676)

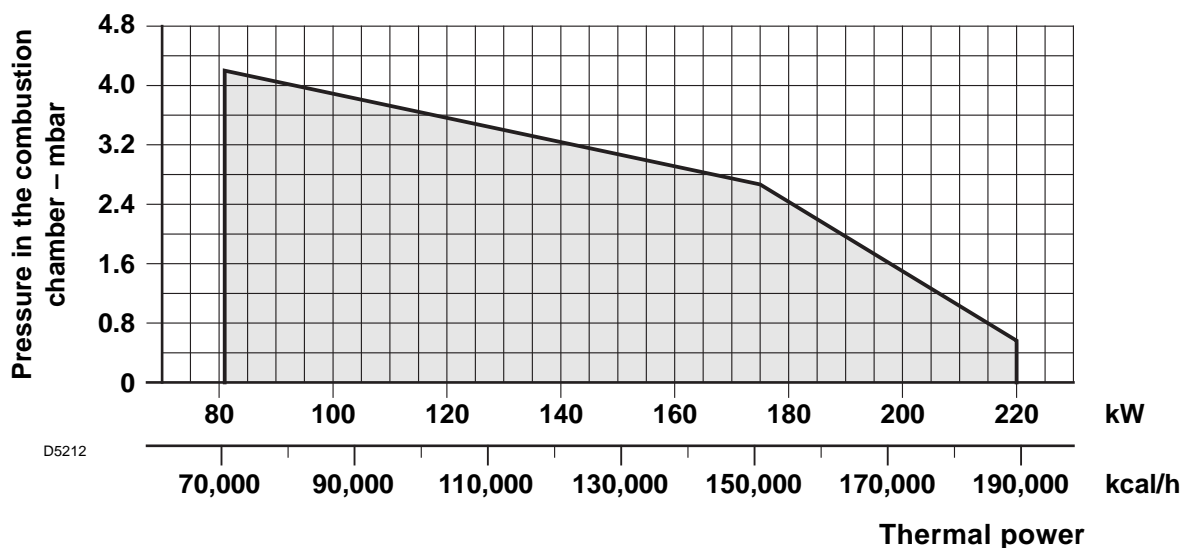

TEST BOILER

The working field has been defined according to EN 676 standard.

COMMERCIAL BOILERS

The burner-boiler matching is assured if the boiler conforms to EN 303 and the combustion chamber dimensions are similar to those shown in the diagram EN 676. For applications where the boiler does not conform to EN 303, or where the combustion chamber is much smaller than the dimensions given in EN 676, please consult the manufacturers.

CORRELATION BETWEEN GAS PRESSURE AND BURNER OUTPUT

To obtain the maximum output, a gas head pressure of 6.9 mbar is measured (M2, see chapter 3.3, page 4) with the combustion chamber at 0 mbar using gas G20 with a net heat value of 10 kWh/Nm³ (8,570 kcal/Nm³).

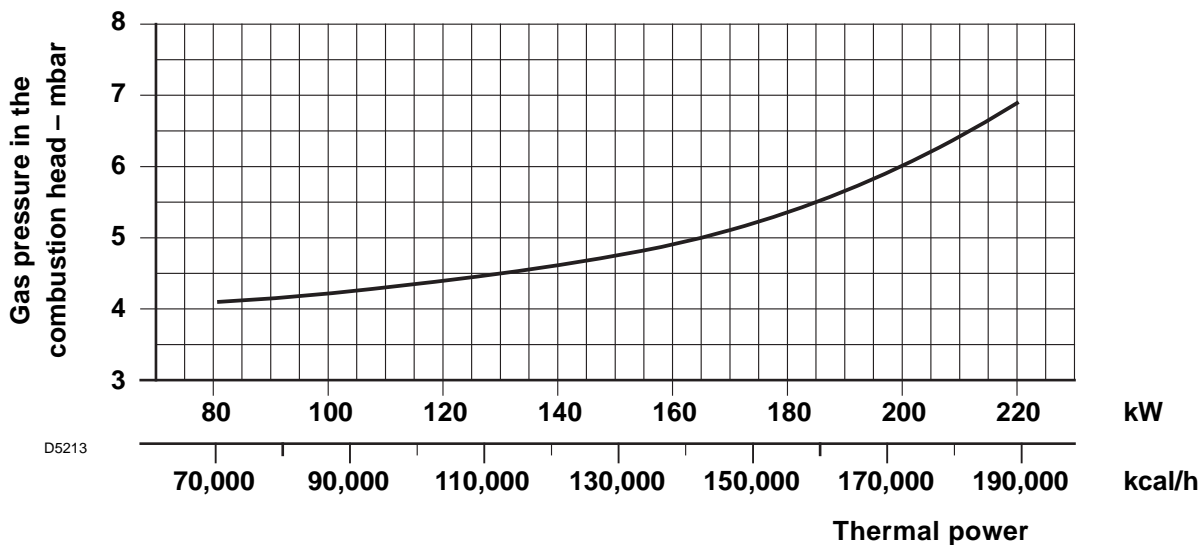

3. INSTALLATION

THE BURNER MUST BE INSTALLED IN CONFORMITY WITH LEGISLATION AND LOCAL STANDARDS.

3.1 BOILER FIXING

IMPORTANT

Boiler door must have a max. thickness of **100 mm**, refractory lining included.

If thickness is greater (**max. 260 mm**), a combustion head extension must be fitted, which is supplied separately.

- Separate the combustion-head assembly from the burner body by removing nut (1) and removing group (A).
- Fix the head assembly group (B) to the boiler (2) insert the supplied insulating gasket (3).

HINGE ASSEMBLY

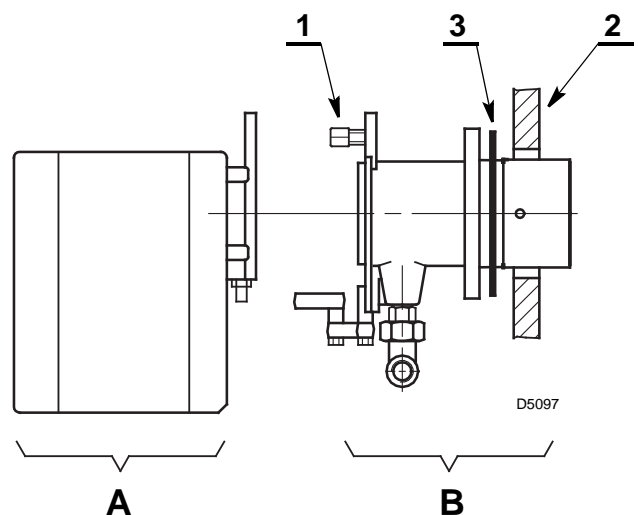
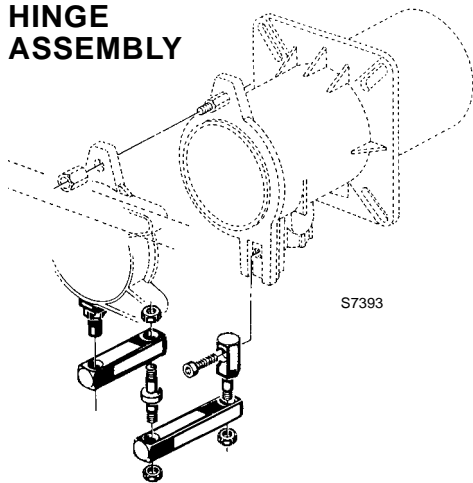

3.2 PROBE - ELECTRODE POSITIONING

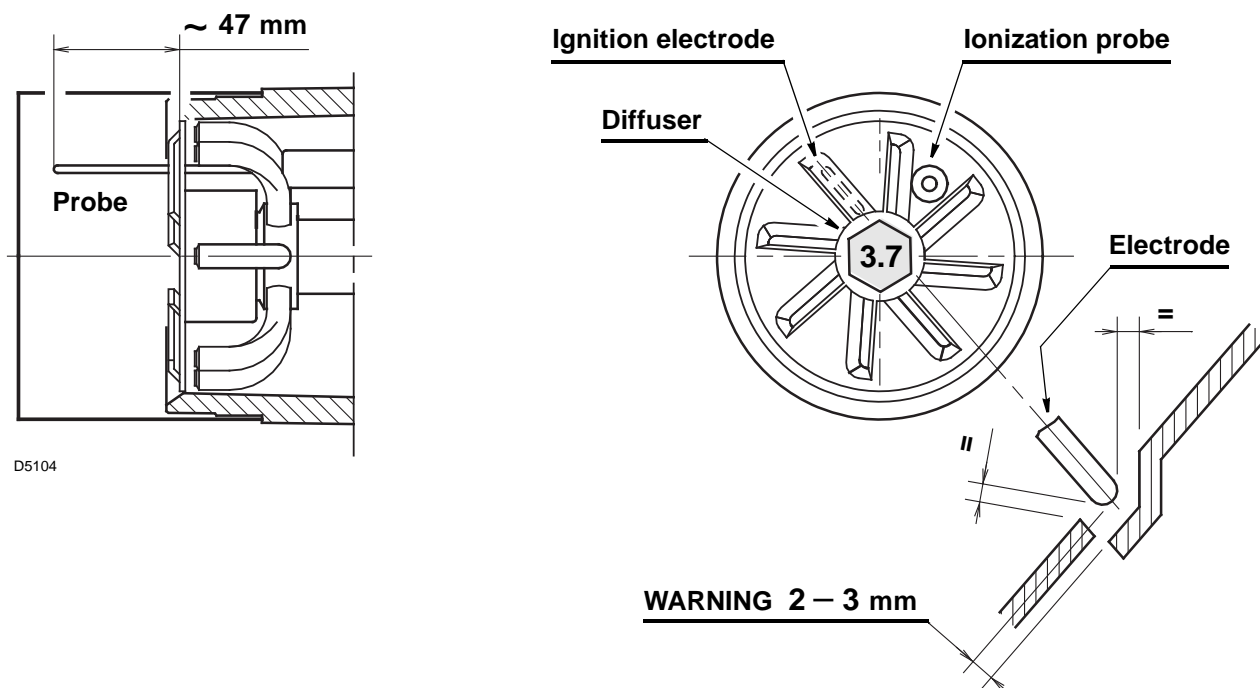

3.3 GAS FEEDING LINE

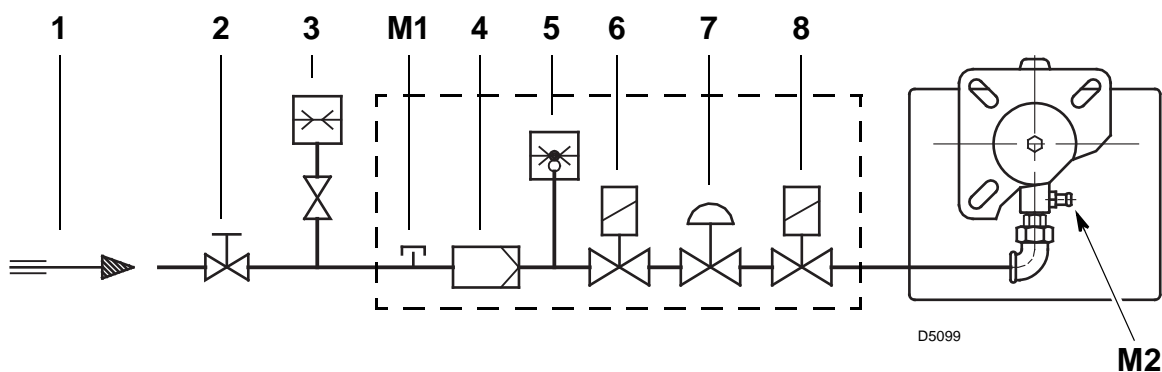

- 1 – Gas supply pipe
- 2 – Manual cock (supplied by the installer)
- 3 – Gas pressure gauge (supplied by the installer)
- 4 – Filter
- 5 – Gas pressure switch
- 6 – Safety valve
- 7 – Pressure governor
- 8 – Adjustment valve

- M1 – Gas-supply pressure test point
- M2 – Pressure coupling test point

GAS TRAIN ACCORDING TO EN 676

GAS TRAIN		CONNECTIONS		USE
TYPE	CODE	INLET	OUTLET	
MBDLE 407 B01	3970531	Rp 3/4	Rp 3/4	Natural gas ≤ 180 kW and LPG
MBDLE 410 B01	3970532	Rp 1	Rp 3/4	Natural gas and LPG

The gas train is supplied separately, for its adjustment see the enclosed instructions.

3.4 ELECTRICAL WIRING

3.4.1 STANDARD ELECTRICAL WIRING

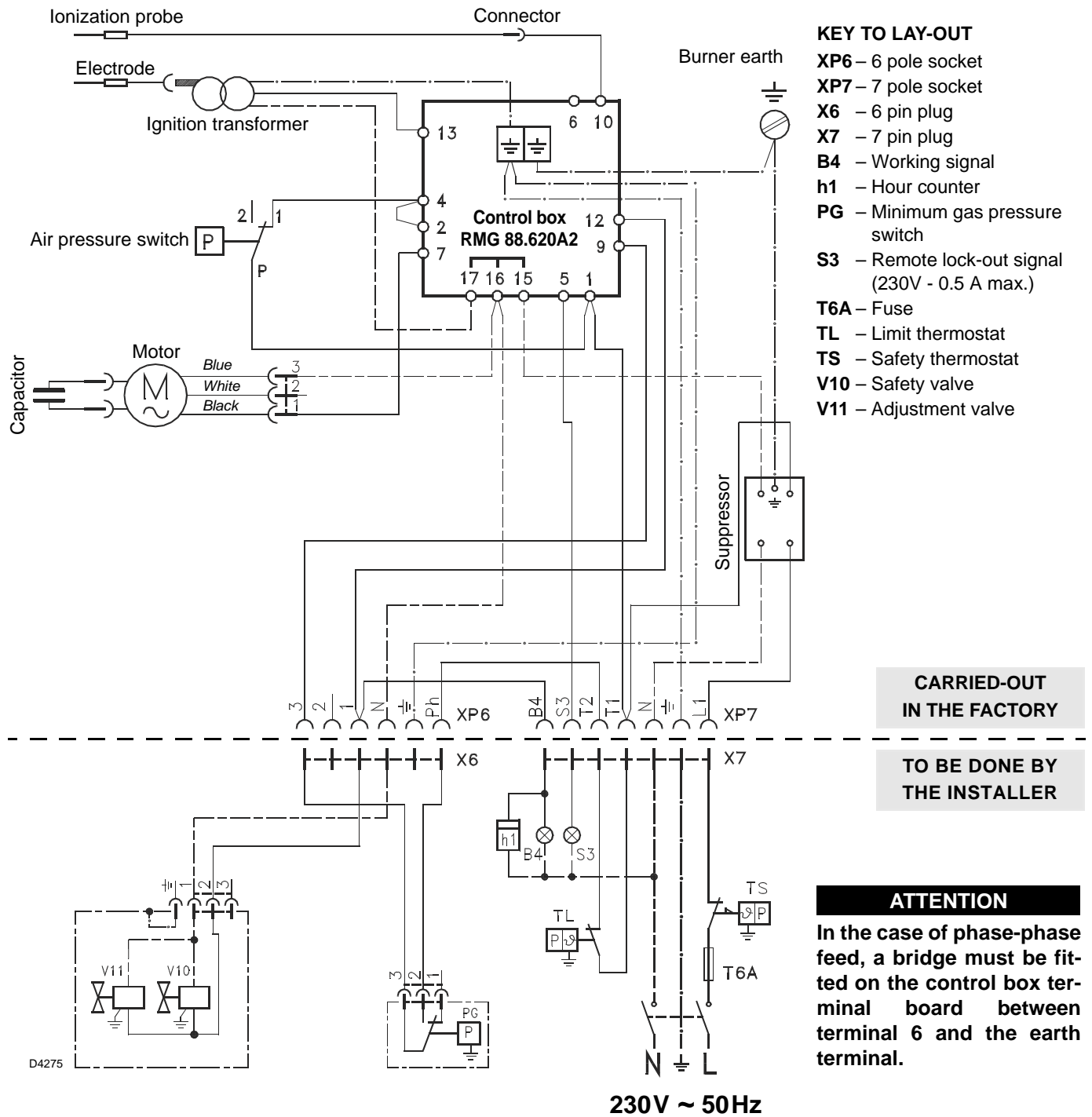

ATTENTION:

- Do not swap neutral and phase over, follow the diagram shown carefully and carry out a good earth connection.
- The section of the conductors must be at least 1mm . (Unless requested otherwise by local standards and legislation).
- The electrical wiring carried out by the installer must be in compliance with the rules in force in the country.
- Verify that the burner stops by operating the boiler control thermostats and that the burner locks out by separating the red ionisation probe lead connector.

NOTES

The burners have been type-approved for intermittent operation. This means they must stop at least once every 24 hours in order to allow the electrical control box to check its efficiency on start-up. The boiler limit thermostat (TL) normally ensures the burner halts. If this does not happen a time switch halting the burner at least once every 24 hours must be applied in series to limit thermostat (TL).

3.4.2 ELECTRICAL WIRING WITH GAS LEAK CONTROL DEVICE (DUNGS VPS 504)

KEY TO LAY-OUT

- X6 – 6 pin plug
- X7 – 7 pin plug
- B4 – Working signal
- h1 – Hour counter
- PG – Minimum gas pressure switch
- S3 – Remote lock-out signal (230V - 0.5 A max.)
- T6A – Fuse
- TL – Limit thermostat
- TS – Safety thermostat
- V10 – Safety valve
- V11 – Adjustment valve

TO BE DONE BY THE INSTALLER

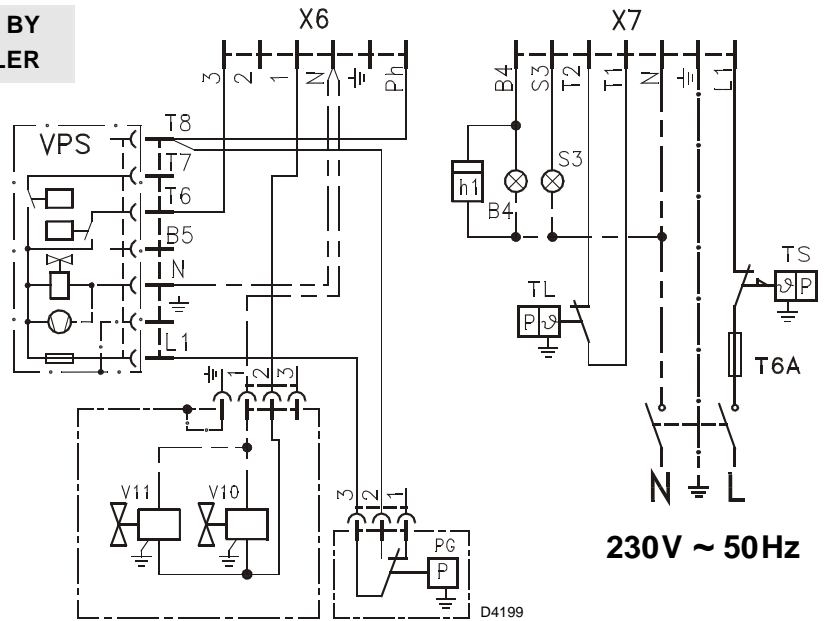

4. WORKING

4.1 COMBUSTION ADJUSTMENT

In conformity with Efficiency Directive 92/42/EEC the application of the burner on the boiler, adjustment and testing must be carried out observing the instruction manual of the boiler, including verification of the CO and CO₂ concentration in the flue gases, their temperatures and the average temperature of the water in the boiler.

To suit the required appliance output, choose the proper setting of the combustion head, and the air damper opening.

4.2 COMBUSTION HEAD SETTING

Loose the screw (A), move the elbow (B) so that the rear plate of the coupling (C) coincides with the set point.

Tighten the screw (A).

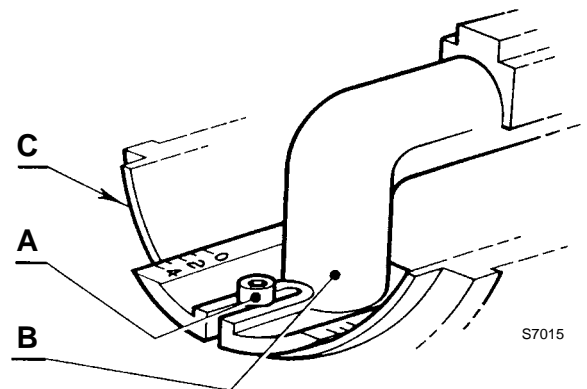

Example:

The burner is installed on a 155 kW boiler with an efficiency of 90%, the burner input is about 172 kW using the diagram, the combustion set point is 3.

The diagram is to be used only for initial settings, to improve air pressure switch operation or improve combustion, it may be necessary to reduce this setting (*set point toward position 0*).

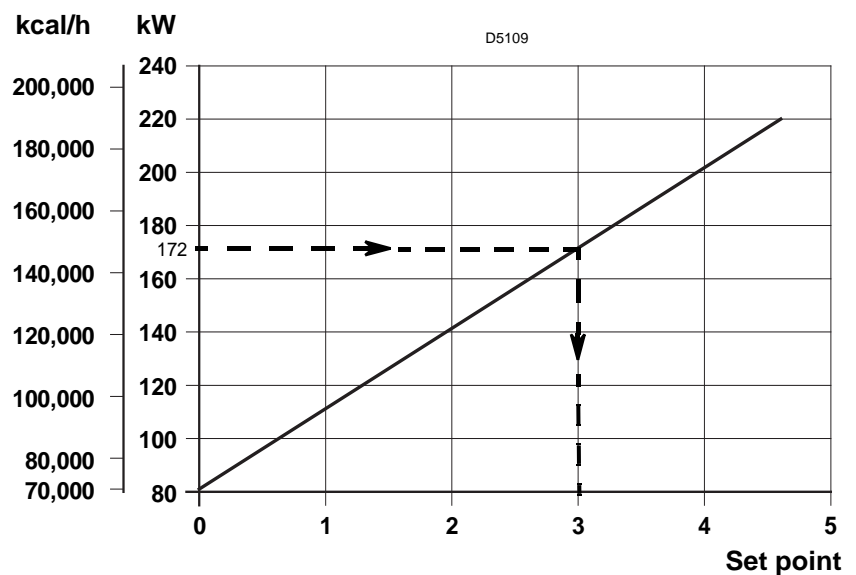

4.3 AIR DAMPER SETTING

The regulation of the air-rate is made by adjusting the air damper (1), after loosening the screws (2).

When the optimal regulation is reached, **screw tight the screws (2)**.

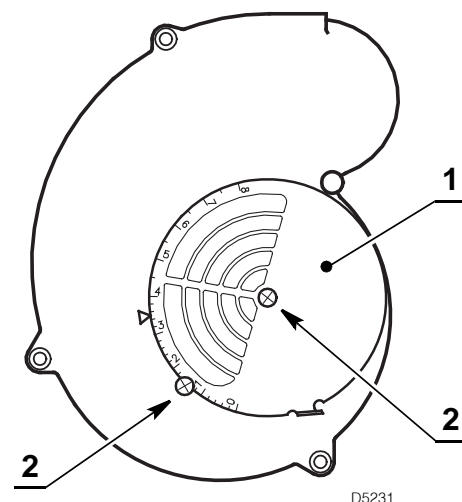

4.4 COMBUSTION CHECK

It is advisable to set the burner according to the type of gas used and following the indications of the table:

EN 676		AIR EXCESS: max. output $\lambda \leq 1.2$ – min. output $\lambda \leq 1.3$			
GAS	Theoretical max. CO ₂ 0 % O ₂	Setting CO ₂ %		CO mg/kWh	NO _x mg/kWh
		$\lambda = 1.2$	$\lambda = 1.3$		
G 20	11.7	9.7	9.0	≤ 100	≤ 170
G 25	11.5	9.5	8.8	≤ 100	≤ 170
G 30	14.0	11.6	10.7	≤ 100	≤ 230
G 31	13.7	11.4	10.5	≤ 100	≤ 230

IONIZATION CURRENT

The minimum current necessary for the control box operation is 3 μ A.

The burner normally supplies a higher current value, so that no check is needed. However, if you want to measure the ionization current, you must open the connector fitted to the red wire and insert a microammeter.

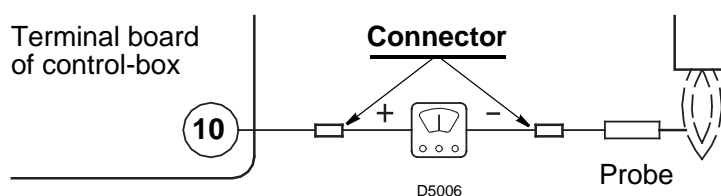

4.5 AIR PRESSURE SWITCH

The air pressure switch is set after all other adjustments have been made. Begin with the switch at the lowest setting. With the burner working at the minimum output, adjust the dial clockwise, increasing its value until the burner shuts down. Now reduce the value by one set point, turning the dial anti-clockwise.

Check for reliable burner operation, if the burner shuts down, reduce the value by a half set point.

Attention:

To comply with the EN 676 standard, the air pressure switch must operate when the CO value exceeds 1% (10,000 ppm). To check this, insert a combustion analyser in the flue, slowly reduce the burner air setting and verify that the burner shuts down by the action of the air pressure switch before the CO value exceeds 1%.

4.6 BURNER START-UP CYCLE

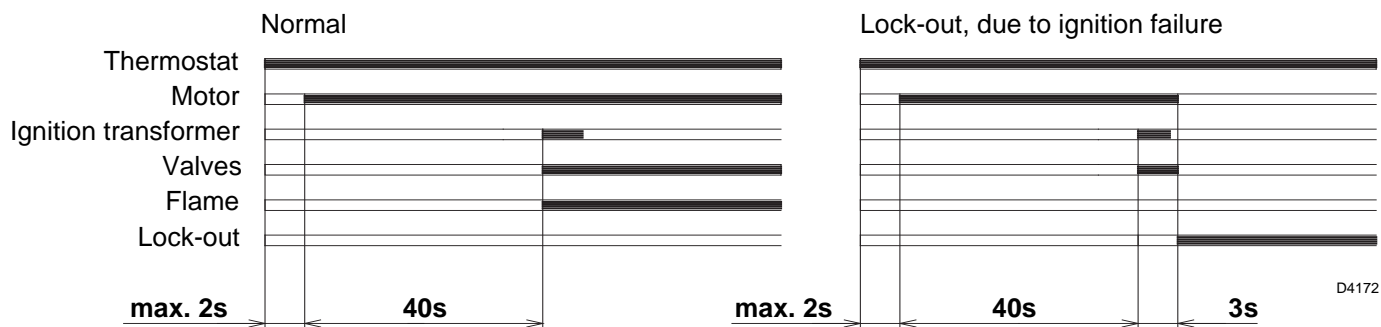

When flame-failure occurs during working, shut down takes place within one second.

4.7 START-UP CYCLE DIAGNOSTICS

During start-up, indication is according to the following table:

COLOUR CODE TABLE	
Sequences	Colour code
Pre-purging	● ● ● ● ● ● ● ● ● ● ● ●
Ignition phase	● ○ ● ○ ● ○ ● ○ ● ○ ●
Operation, flame ok	□ □ □ □ □ □ □ □ □ □ □ □
Operating with weak flame signal.	□ ○ □ ○ □ ○ □ ○ □ ○
Electrical supply lower than ~ 170V	● ▲ ● ▲ ● ▲ ● ▲ ● ▲ ●
Lock-out	▲ ▲ ▲ ▲ ▲ ▲ ▲ ▲ ▲ ▲
Extraneous light	▲ □ ▲ □ ▲ □ ▲ □ ▲ □ ▲
Index:	○ Off ● Yellow □ Green ▲ Red

4.8 RESETTING THE CONTROL BOX AND USING DIAGNOSTICS

The control box features a diagnostics function through which any causes of malfunctioning are easily identified (indicator: **RED LED**).

To use this function, you must wait at least 10 seconds once it has entered the safety condition (**lock-out**), and then press the reset button.

The control box generates a sequence of pulses (1 second apart), which is repeated at constant 3-second intervals.

Once you have seen how many times the light pulses and identified the possible cause, the system must be reset by holding the button down for between 1 and 3 seconds.

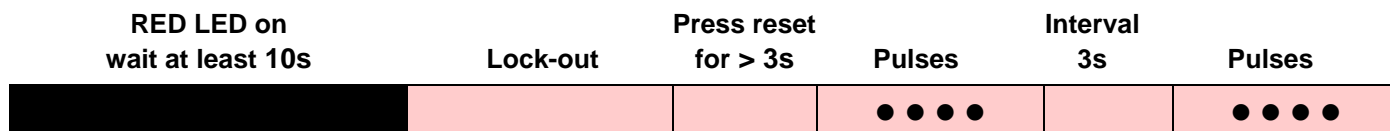

The methods that can be used to reset the control box and use diagnostics are given below.

RESETTING THE CONTROL BOX

To reset the control box, proceed as follows:

- Hold the button down for between 1 and 3 seconds.
The burner restarts after a 2-second pause once the button is released.
If the burner does not restart, you must make sure the limit thermostat is closed.

VISUAL DIAGNOSTICS

Indicates the type of burner malfunction causing lock-out.

To view diagnostics, proceed as follows:

- Hold the button down for more than 3 seconds once the red LED (burner lock-out) remains steadily lit.
A yellow light pulses to tell you the operation is done.
Release the button once the light pulses. The number of times it pulses tells you the cause of the malfunction, indicated in the table below.

SOFTWARE DIAGNOSTICS

Reports the life of the burner by means of an optical link with the PC, indicating hours of operation, number and type of lock-outs, serial number of control box etc ...

To view diagnostics, proceed as follows:

- Hold the button down for more than 3 seconds once the red LED (burner lock-out) remains steadily lit.
A yellow light pulses to tell you the operation is done.
Release the button for 1 second and then press again for over 3 seconds until the yellow light pulses again.
Once the button is released, the red LED will flash intermittently with a higher frequency: only now can the optical link be activated.

Once the operations are done, the control box's initial state must be restored using the resetting procedure described above.

BUTTON PRESSED FOR	CONTROL BOX STATUS
Between 1 and 3 seconds	Control box reset without viewing visual diagnostics.
More than 3 seconds	Visual diagnostics of lock-out condition: (LED pulses at 1-second intervals).
More than 3 seconds starting from the visual diagnostics condition	Software diagnostics by means of optical interface and PC (hours of operation, malfunctions etc. can be viewed)

The sequence of pulses issued by the control box identifies the possible types of malfunction, which are listed in the table below.

SIGNAL	PROBABLE CAUSE
2 pulses ● ●	The flame does not stabilise at the end of the safety time: – faulty ionisation probe; – faulty or soiled gas valves; – neutral/phase exchange; – faulty ignition transformer – poor burner regulation (insufficient gas).
3 pulses ● ● ●	Minimum air pressure switch does not close: – make sure VPS trips to produce lockout; – air pressure switch faulty; – air pressure switch incorrectly regulated; – fan motor does not run; – maximum air pressure switch operating.
4 pulses ● ● ● ●	Min. air pressure switch does not open or light in the chamber before firing: – air pressure switch faulty; – air pressure switch incorrectly regulated.
7 pulses ● ● ● ● ● ● ●	Loss of flame during operations: – poor burner regulation (insufficient gas); – faulty or soiled gas valves; – short circuit between ionisation probe and earth.
10 pulses ● ● ● ● ● ● ● ● ● ● ● ●	– Wiring error or internal fault.

5. WARNINGS TO AVOID BURNOUT OR BAD COMBUSTION OF THE BURNER

- 1 – When the burner is stopped, the smoke pipe must be opened and effect a natural draught in the combustion chamber. If the smoke pipe is closed, the burner must be drawn back till the extraction of blast tube from the furnace. Before operating in this way take the voltage off.
- 2 – The place, where the burner works, must have same openings suitable for the passage of air necessary for combustion. To be sure about this, you have to control CO₂ and CO in the exhaust gases with all the windows and doors closed.
- 3 – If in the place, where the burner works, there are air-breathings, check the existence of air-input openings with dimensions suitable for the necessary air-exchange. In any case check that, when the burner is stopped, the air-breathings do not draw warm smokes from pipes through the burner.

6. MAINTENANCE

The burner requires periodic maintenance carried out by a qualified and authorised technician **in conformity with legislation and local standards**.

Maintenance is essential for the reliability of the burner, avoiding the excessive consumption of fuel and consequent pollution.

Before carrying out any cleaning or control always first switch off the electrical supply to the burner acting on the main switch of the system.

THE BASIC CHECKS ARE:

Leave the burner working without interruption for 10 min., checking the right settings of all the components stated in this manual. Then carry out a combustion check verifying:

- CO₂ (%) content
- Smoke temperature at the chimney
- CO content (ppm).

7. FAULTS / SOLUTIONS

Here below you can find some causes and the possible solutions for some problems that could cause a failure to start or a bad working of the burner. A fault usually makes the lock-out lamp light which is situated inside the reset button of the control box (9, fig. 1, page 1).

When lock out lamp lights the burner will attempt to light only after pushing the reset button. After this if the burner functions correctly, the lock-out can be attributed to a temporary fault.

If however the lock out continues the cause must be determined and the solution found.

BURNER STARTING DIFFICULTIES

Signal	Problem	Possible cause	Recommended remedy
2 blinks ● ●	Once the pre-purging phase and safety time have passed, the burner goes into lockout without the appearance of the flame	1 - The operation solenoid lets little gas through 2 - One of the two solenoid valves does not open. 3 - Gas pressure too low 4 - Ignition electrode incorrectly adjusted 5 - Electrode grounded due to broken . insulation 6 - High voltage cable defective 7 - High voltage cable deformed by high temperature 8 - Ignition transformer defective 9 - Incorrect valve or transformer electrical wiring 10 - Defective control box 11 - A closed valve upline the gas train . 12 - Air in pipework 13 - Gas valves unconnected or with . . . interrupted coil	Increase Replace Increase pressure at governor Adjust, see page 4 Replace Replace Replace and protect Replace Check Replace Open Bleed air Check connections or replace coil
3 blinks ● ● ●	The burner does not switch on, and the lockout appears	14 - Air pressure switch in operating position	Adjust or replace
	The burner switches on, but then stops in lock-out	- Air pressure switch inoperative due to insufficient air pressure: 15 - Air pressure switch incorrectly adjusted. 16 - Pressure switch pressure test point pipe blocked 17 - Poorly adjusted head 18 - High pressure in the furnace	Adjust or replace Clean Adjust Connect air pressure switch to fan suction line
	Lockout during pre-purging phase	19 - Defective motor control contactor . . (only three-phase version) 20 - Defective electrical motor 21 - Motor lockout (defective electrical motor)	Replace Replace Replace
4 pulses ● ● ● ●	The burner switches on, but then stops in lock-out	22 - Flame simulation	Replace the control box
	Lockout when burner stops	23 - Permanent flame in the combustion head or flame simulation	Eliminate persistence of flame or replace control box

Signal	Problem	Possible cause	Recommended remedy
7 blinks ● ● ● ● ● ● ●	The burner goes into lockout immediately following the appearance of the flame	24 - The operation solenoid lets little gas through 25 - Ionisation probe incorrectly adjusted 26 - Insufficient ionisation (less than 5 A) 27 - Earth probe. 28 - Burner poorly grounded 29 - Phase and neutral connections inverted 30 - Defective flame detection circuit. . .	Increase Adjust, see page 4 Check probe position Withdraw or replace cable Check grounding Invert them Replace the control box
	Burner goes into lockout during operation	31 - Probe or ionisation cable grounded	Replace worn parts
10 blinks ● ● ● ● ● ● ● ● ● ●	The burner does not switch on, and the lockout appears	32 - Incorrect electrical wiring	Check
	The burner goes into lockout	33 - Defective control box 34 - Presence of electromagnetic disturbances in the thermostat lines	Replace Filter or eliminate
No blink	The burner does not start	35 - No electrical power supply	Close all switches - Check connections
		36 - A limiter or safety control device is open	Adjust or replace
		37 - Line fuse blocked	Replace
		38 - Defective control box	Replace
		39 - No gas supply.	Open the manual valves between contactor and train
The burner continues to repeat the start-up cycle, without lockout	40 - Mains gas pressure insufficient . . .	Contact your GAS COMPANY	
	41 - Minimum gas pressure switch fails to close	Adjust or replace	
Ignition with pulsations	The burner continues to repeat the start-up cycle, without lockout	42 - The gas pressure in the gas mains lies very close to the value to which the minimum gas pressure switch has been set. The sudden drop in pressure after valve opening causes temporary opening of the pressure switch itself, the valve immediately closes and the burner comes to a halt. Pressure increases again, the pressure switch closes again and the ignition cycle is repeated. And so on	Reduce the minimum gas pressure switch intervention pressure. Replace the gas filter cartridge.
		43 - Poorly adjusted head	Adjust. See page 6
		44 - Ignition electrode incorrectly adjusted	Adjust, see page 4
		45 - Incorrectly adjusted fan air damper: too much air	Adjust
46 - Output during ignition phase is too high	46 - Output during ignition phase is too high	46 - Output during ignition phase is too high	Reduce

N.B.: If problems still occur after all of the above checks have been made, check the electrical connections on the plug and sockets, the damper and burner motor, gas control wiring ignition transformer and external interlocks, if the burner still fails to function, replace the control box.

NORMAL OPERATION / FLAME DETECTION TIME

The control box has a further function to guarantee the correct burner operation (signal: **GREEN LED** permanently on).

To use this function, wait at least ten seconds from the burner ignition and then press the control box button for a minimum of 3 seconds.

After releasing the button, the GREEN LED starts flashing as shown in the figure below.

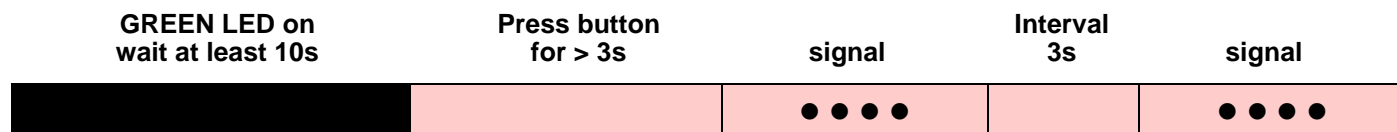

The pulses of the LED constitute a signal spaced by approximately 3 seconds.

The number of pulses will measure the probe DETECTION TIME since the opening of gas valves, according to the following table:

SIGNAL	FLAME DETECTION TIME
1 blink ●	0.4s
2 blinks ● ●	0.8s
6 blinks ● ● ● ● ● ●	2.8s

This is updated in every burner start-up. Once read, the burner repeats the start-up cycle by briefly pressing the control box button.

WARNING

If the result is > 2s, ignition will be retarded. Check the adjustment of the hydraulic brake of the gas valve, the air damper and the combustion head adjustment.

KIT INTERFACE ADAPTER RMG TO PC Code 3002719